

Disk Recorder/Reproducer

Model 80

Model 80e

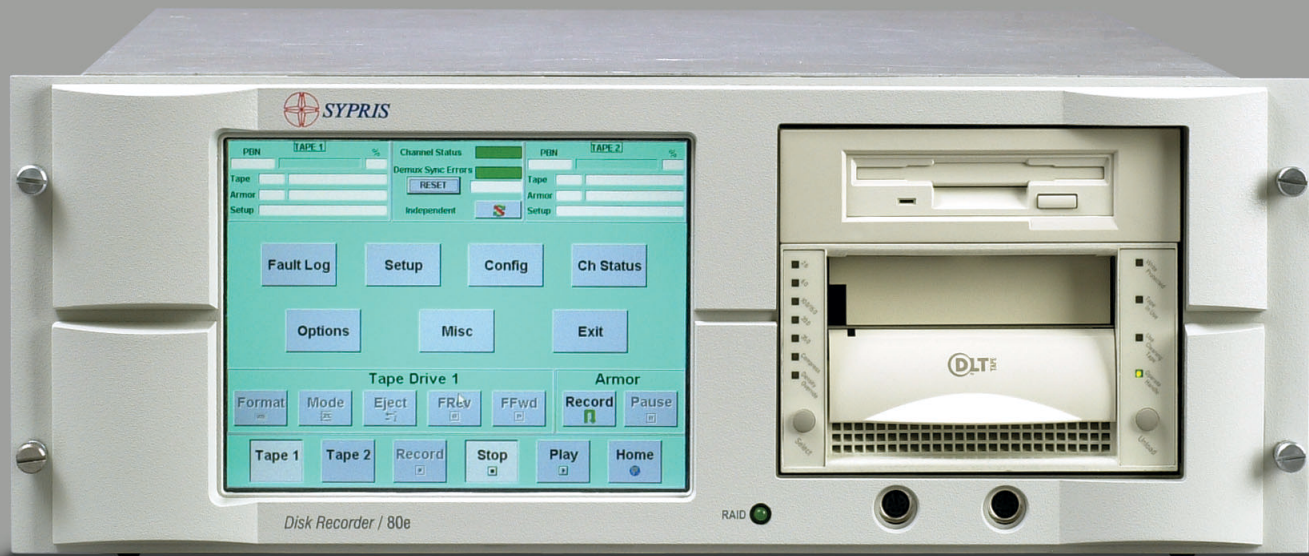

Features/Benefits

- ▲ Emulates Model 64 recorder
- ▲ Controls ARMOR multiplexer
- ▲ Records up to 560 GBytes to an internal RAID
- ▲ Front-panel touch screen control
- ▲ Stores data as Windows NT™ files
- ▲ Drag-and-drop file transfers
- ▲ Standard Windows™ networking
- ▲ Flexible storage options
- ▲ 10baseT/100baseT Ethernet
- ▲ Internal archival drives
- ▲ SCSI port for external storage
- ▲ Records up to 9 TBytes over network

Disk Recorder/Reproducer Model 80/Model 80e

Overview

The Model 80 and 80e are disk-based IRIG recorder/reproducers that emulate the Sypris Model 64/ buffered VLDS line of tape recorders in combination with an ARMOR data multiplexer.

They make up a complete, closely integrated system for recording, storing, and archiving multiple streams of analog and digital instrumentation data.



Model 80e with ARMOR, typical configuration.

For information on the ARMOR data multiplexer, request D-2364 from the sales office or website listed on the last page.

All multiplexing, record, and reproduce functions can be set up, controlled, and monitored with the front-panel touch screen. A keyboard and mouse can be attached if desired.

The Model 80 and Model 80e are similar in function and are interchangeable. The Model 80e offers faster data rates and greater noise immunity.

The recorder/reproducer stores acquired data to an internal RAID. The data can then be archived on internal, removable-media devices and transferred

across a network. Standard network protocols such as TCP/IP, FTP, and Telnet can be used. The data can be demultiplexed using optional software in the Model 80. It can also be demultiplexed and played back with the ARMOR. Optionally, the Model 80 or 80e can be configured as a single

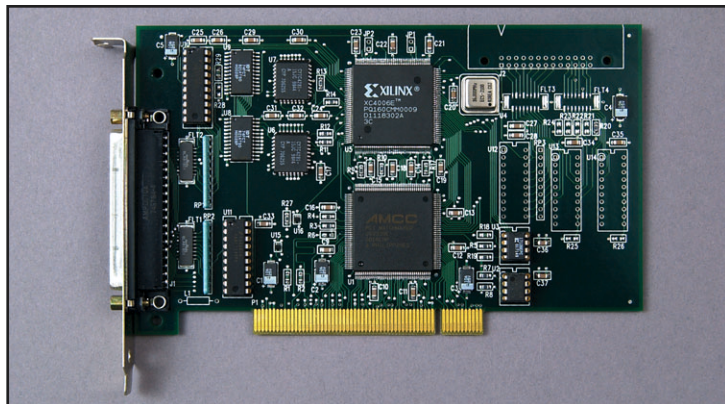

PCI-V64 card.

data-channel serial recorder with two auxiliary channels for time code, voice, or other information.

An optional PCI-V64 card and supporting software in the disk recorder transparently emulate the Model 64 tape drive's 8-bit parallel data bus (native I/O interface). An optional tunable bit synchronizer (9917) is also available as a PCI expansion card to derive a clock from a serial PCM stream.

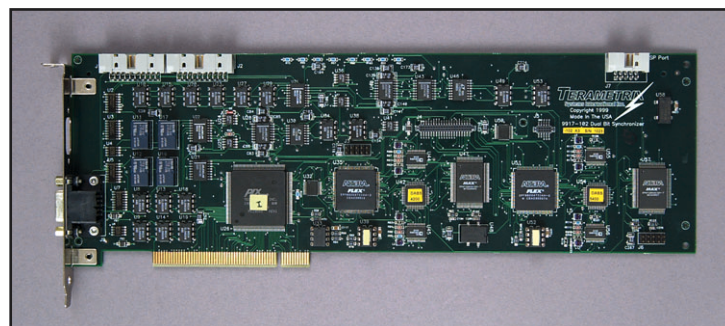

9917 Bit Synchronizer.

For information on the 9917 Bit Synchronizer, request D-2602 from the sales office or website listed on the last page.

The disk recorders are based on a Pentium®-class, Windows NT™ workstation, complete with system



Removable RAID drives for security requirements.

disk, RAM, and floppy diskette drive. The disk array subsystem has up to four hard drives and a RAID controller. Drives of various capacities are available.

The workstation has on-board IDE and SCSI buses to support the various optional archival storage devices that can be installed in the front-panel drive bays of the disk recorder. Drives for all the selected devices are installed and tested at the factory.

All RAID drives and archival media are removable to meet security requirements.

Disk recorder operations such as Record, Stop, Read Setup From Tape, Play from PBN, Play from IRIG Time, Format, FFWD, FREV, and tape monitor, function identically to those of a Model 64 tape drive that is under ARMOR control.

The Model 80 and 80e run Windows NT™ 4.0, and format data as Windows NT File System (NTFS) files that can be transferred, copied, and backed up using the familiar Windows desktop. Data can be captured as a single file or as a series of files that are automatically numbered sequentially.

The Model 80 and 80e are the same compact size as the Model 64 series recorders, and use identical connectors. The Model 80 and Model 64 are interchangeable in a data acquisition system.

Sypris Technology

These disk recorders are members of a long line of Sypris products for acquiring and storing data in

high-performance systems. They offer an alternative to tape recording in applications requiring fast data rates and high storage densities.

Because each disk recorder can be ordered with a choice of many different types of archival storage devices installed, it has the flexibility to meet a range of storage requirements - all in a single, compact unit.

Commercial off-the-shelf components are used throughout the Model 80 and Model 80e. This design approach reduces cost and complexity. It also enhances reliability by assuring the availability of parts and by simplifying testing and maintenance.

Product Highlights

A Model 80 or 80e is functionally equivalent to a tape recorder such as the Sypris Model 64. An ARMOR data multiplexer can be used with the disk recorder to combine multiple channels of asynchronous data into a single digital stream. The ARMOR also handles data conversions, time code, rate control, and encoding formats for the recorder.

The disk recorder appears to the ARMOR as a Model 64, and provides a graphical user interface for controlling the ARMOR, as well as all record/reproduce operations and archival storage devices.

Its front-panel touch screen display can be used without a keyboard and mouse. This saves rack space and simplifies control of all system elements.

The disk recorder capacity is currently set at a minimum of 54 GBytes of data (Model 80) and 72 GBytes (Model 80e) to an internal RAID, formatting the data as Windows NT™ file system (NTFS) files. Transferring a data file is as simple as dragging and dropping it on a desktop icon representing a front-panel drive or a network drive.

Standard Windows™ networking is supported, on 10baseT/100baseT Ethernet with TCP/IP, FTP, and Telnet.

Archival, removable-media drives such as DLT, CD-R and – RW, 4 mm or 8 mm tape, and DVD can be installed in the internal drive bays.

A SCSI port supports external devices drives such as a Model 64 or Sony DTF.

Operation

The disk recorder has setup and control software that enable it to function as the host computer for the ARMOR. All recorder and ARMOR operations can be set up, monitored, and controlled with the front-panel touchscreen display. Optionally, a keyboard and mouse can be connected for interacting with the display.

Recording can be set up to format data as a single file for a whole session, or as sequentially numbered files that are created automatically each time recording begins.

Data files can be copied from the internal RAID to the optional archival drives by dragging and dropping them on the front-panel desktop display. Drives are given logical drive IDs to simplify transferring data files.

Additionally, data can be copied to an external SCSI storage device. It can also be transferred to remote equipment via Ethernet, using TCP/IP protocols such as FTP, and Telnet.

Applications

The Model 80 and Model 80e excel in real-time data-acquisition applications, for capturing real-time data such as telecom signals, satellite imagery, radar, sonar, and flight-test telemetry. The disk recorders can be integrated with other Sypris Data Systems products to meet a wide range of data transfer rates, bandwidths, and storage capacities.

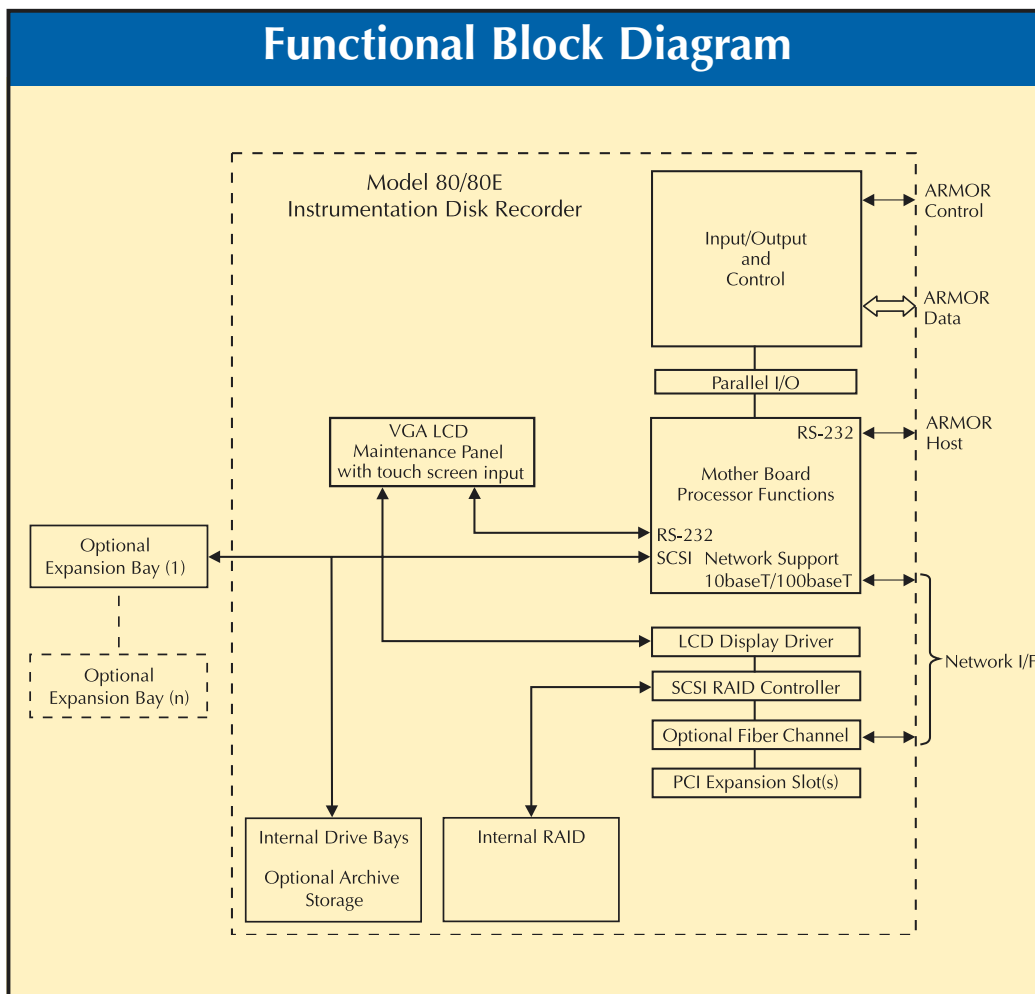

Controls and Indicators

All recorder functions are controlled via a multi-colored touch screen using standard industry commands and menus.

Screens

Users can access any screen in the hierarchy by selecting one of the display choices. The menu screen is accessible from any lower level screen simply by selecting the “home” icon. Each screen displays status information for the multiplexer/recorder and provides access to control commands via the appropriate icon.

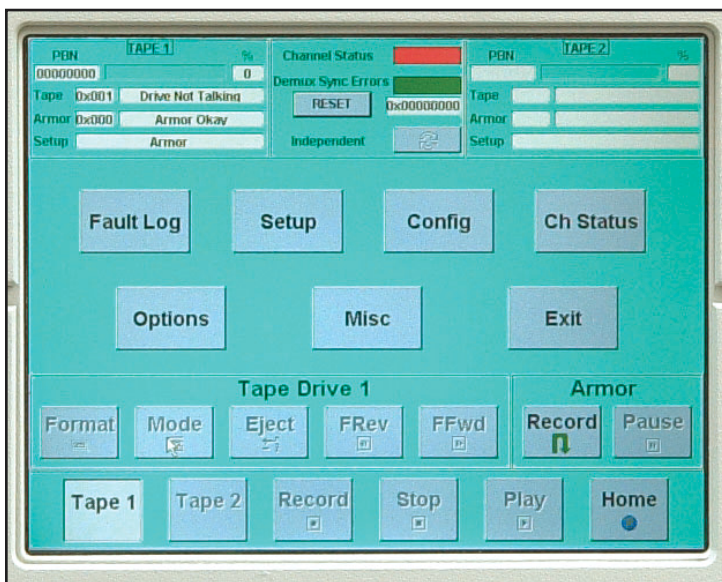

Subsystem Description

The internal disk array is configured as a RAID level-0 striped disk array. The RAID can be ordered with up to four internal drives of various capacities, such as 18, 36, 72 or 140 GBytes. Total RAID capacity is the sum of the capacities of the installed drives.

Expansion Bay Options

Two different dual-bay SCSI expansion bays are available for the Model 80/80e — a two bay, half-height drive version suitable for removable hard drives, DVD-RAM, SCSI floppy or other archive devices and a two bay, full-height drive configuration for removable RAID and/or additional archive drives. Both options include cables, SCSI termination and power.



Expansion Bays increase capability.

Seven expansion bays made from either configuration may be daisy chained to expand the storage capacity of the Model 80/80e. Both optional expansion bays may be used in the same chain as long as RAID and archive chains are not mixed.

Service and Support

Sypris offers complete technical support assistance via telephone, e-mail and on-site repair, maintenance and training.

Specifications

GENERAL

Data multiplexing front end	ARMOR
Front panel control	VGA LCD with touch screen
Processor	Pentium III Class
Data file format	NT File System (NTFS)
Network support	10baseT/100baseT
Internal archive drive bays	3 half-height bays
Expansion slots	3 PCI slots
Archive drive support	Internal – SCSI and IDE External – SCSI
Compatibility	Data compatible with Model 80, Model 80e Buffered VLDS and Model 64 recorders

SOFTWARE

Windows NT™ 4.0 Workstation
ARMOR setup and control software
File-management utilities
Drivers for installed archival devices

ACCESSORIES

Rackmounting kit
Keyboard and mouse
Serial cable to host connector of ARMOR
Serial cable to tape control connector of ARMOR
Parallel cable to connect Model 80 to data port of ARMOR
Two data cables to connect Model 80e to ARMOR

OPTIONAL ACCESSORIES

Chassis handles

OPTIONAL ARCHIVAL DRIVE CONFIGURATIONS:

The following lists the more popular industry offerings.
Other configurations are also available upon request.

DLT
4mm or 8mm tape
CD-R DVD-RW
CD-RW DVD-RW
DVD-R DVD-RAM

Front-panel-mounted devices connect to the workstation system board via on-board IDE, Ultra-wide SCSI, and/or Ultra2/LVD SCSI interface connectors.

PERFORMANCE

Data rate (streaming)	1 kilobit/sec to 80 Mbits/sec (Model 80) 1 kilobit/sec to 128 Mbits/sec (Model 80e)
Data capacity (max)	72, 144, 288, or 560 GBytes, depending on the capacity of the installed RAID drives
Disk capacity	18, 36, 72 or 140 GBytes

PHYSICAL

Size	7H x 17W x 22.5L-inches (17.78H x 43.18W x 57.15L cm)
Weight (w/o slides)	40 lbs (18.14 kg) typical (with 72 GByte Disk Array and DLT option. Weight depends upon installed options)
Mounting	Standard 19-inch (48.26 cm) RETMA rack mount in 24–30 inch (609.6–762 cm) deep rack with industry-standard slides

POWER

Input voltage	90 to 135 Vac 180 to 270 Vac
Frequency	47 to 63 Hz
Current	1.8A (typical) at 115 Vac

ENVIRONMENTAL

Operating temperature	41 to 104° F (5 to 40° C)
Storage temperature	40 to 158° F (40 to 70° C)
Relative humidity	5 to 80% (non-condensing)

Specifications subject to change without notice.

Dimensions

Model 80/80e

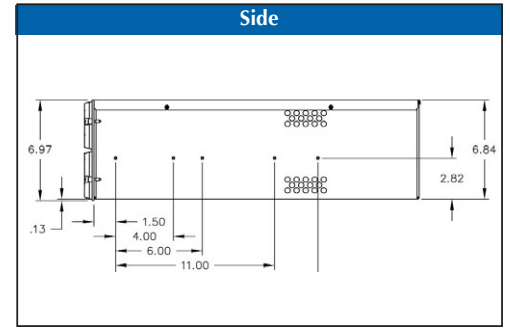
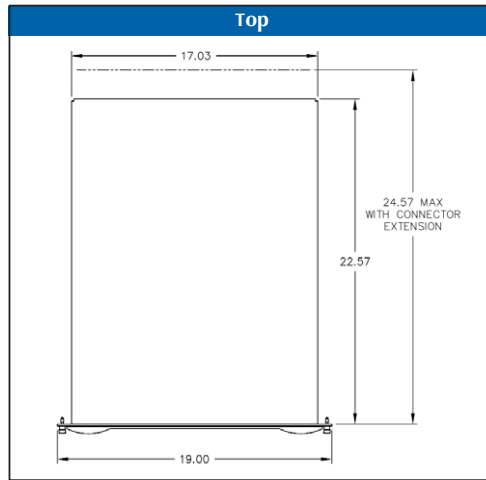
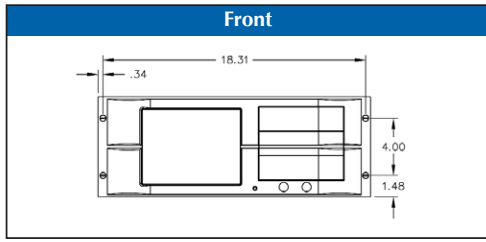

Expansion Bay — Half - height

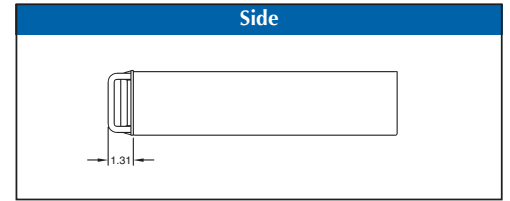
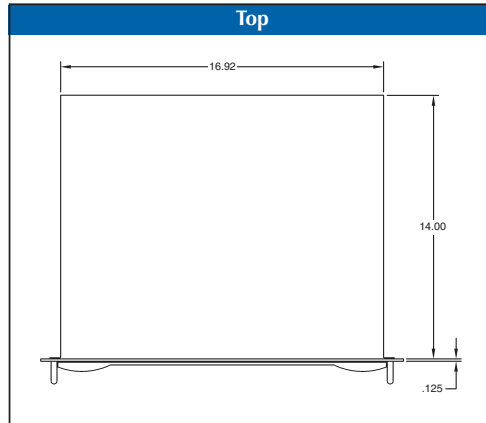
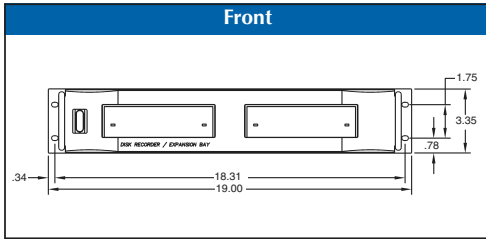

Expansion Bay — Full - height

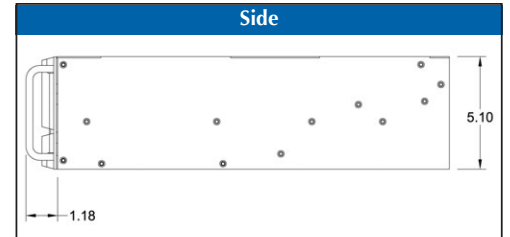
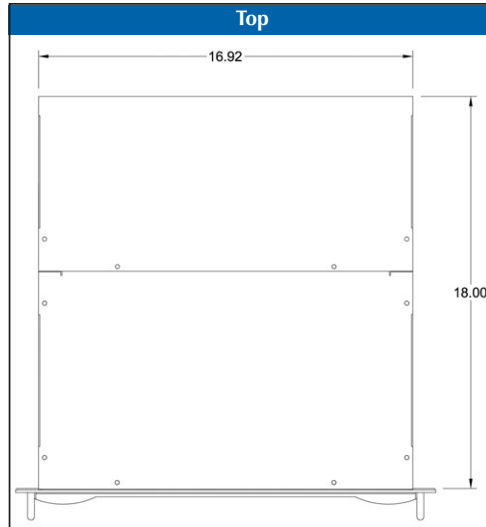
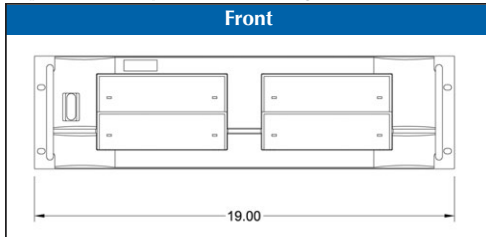

Measurements in inches.

Sypris Data Systems Inc.
605 East Huntington Drive, Monrovia, CA 91016-3636
626-358-9500 • 626-358-9100 Fax

Sales • 1-888-891-3415

To request product catalog, literature and specifications
www.sypris.com • www.syprisdatasystems.com

©Sypris Data Systems Inc. 2003



All trademarks used herein are the property of their respective owners.
D-2424B 0203
ISO 9001 Registered
Printed in USA
